

HARDING
AUTOPARK SYSTEMS



SPEC SHEET

**WÖHR
COMBILIFT
542-2.0**

Independent Access Parking for
Two-Car Stacking with Pit

COMBILIFT 542-2.0

Suitable for condominium and office buildings.
For permanent use only!

In case of short-term users (e.g. for offices, hotels, a.s.o.) technical adjustments are required.
Please contact Harding Autopark Systems!

Load per platform max. 4400 lbs.
(load per wheel max. 1100 lbs.)

Special reinforced units for heavier vehicles are available (see 542-2.6).

X = Door offset (see page 3 for details)

DIMENSIONS

* in this zone, 0% of downward/upward slope in longitudinal and cross direction

** see notes, point 5

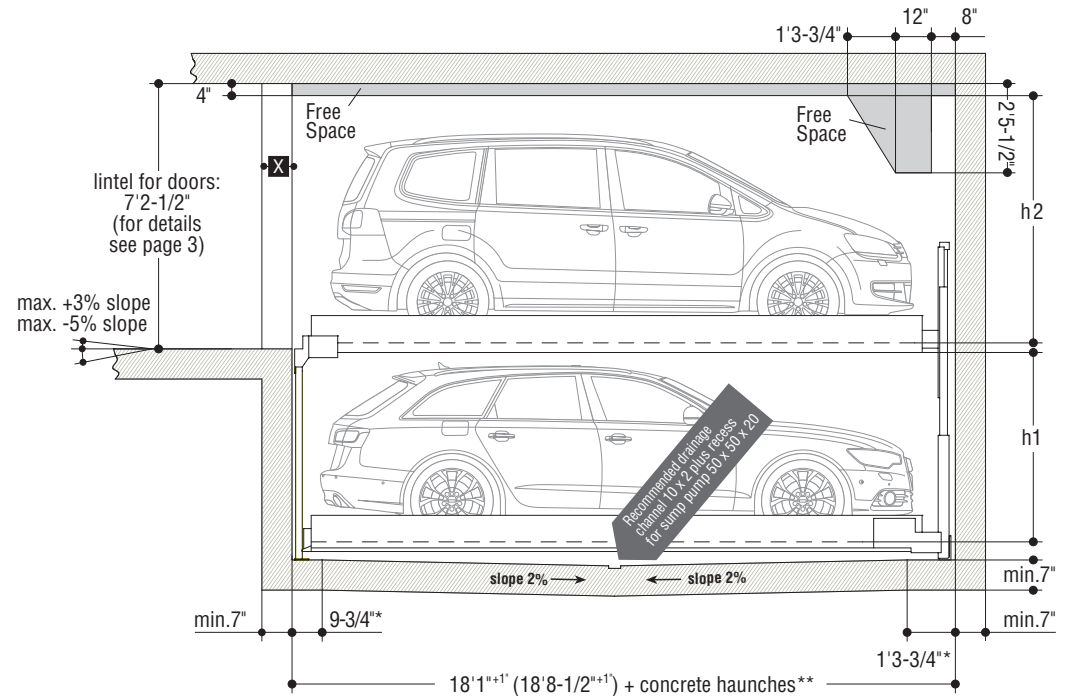

Comfort Type 542 · 2000 kg

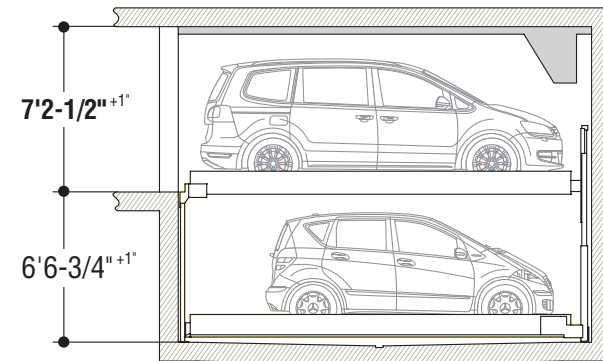

| | CAR HEIGHT | DISTANCE |
|----|---|---------------|
| EL | Cars/Vans up to 6'6-3/4" and 4400 lbs. max. | h2 = 6'8-3/4" |
| LL | Cars/Station wagons up to 5'9" | h1 = 5'10" |

EL = Entrance Level, LL = Lower Level

Compact Type 542 · 2000 kg

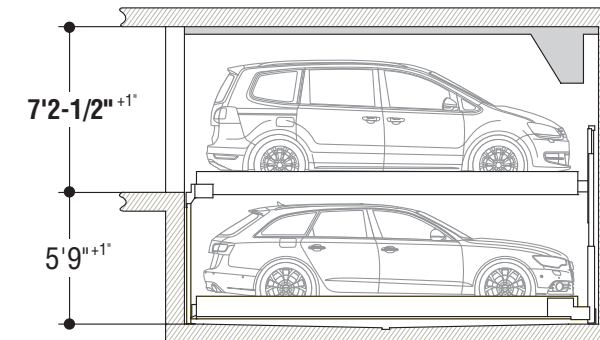

| | CAR HEIGHT | DISTANCE |
|----|---|---------------|
| EL | Cars/Vans up to 6'6-3/4" and 4400 lbs. max. | h2 = 6'8-3/4" |
| LL | Cars/Station wagons up to 4'11" | h1 = 5'1" |

Please pay attention to restricted car heights on lower platforms!

Width Dimensions

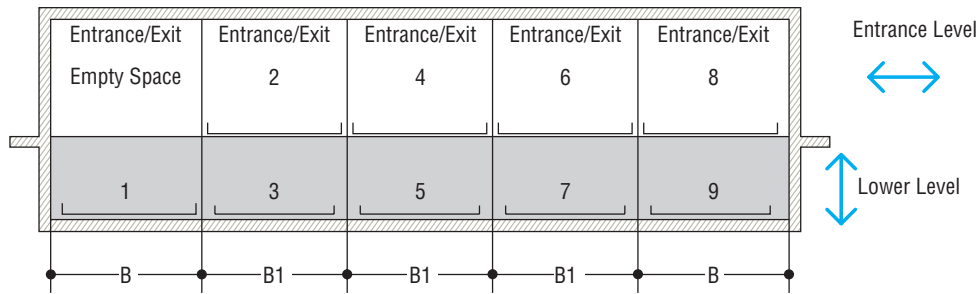

One entry/exit is required on entrance level for each grid.

| SPACE REQUIRED | | GIVES CLEAR PLATFORM WIDTH |
|----------------|----------|----------------------------|
| B | B1 | |
| 8'6-1/2" | 8'2-1/2" | 7'6-1/2" |
| 8'10" | 8'6-1/2" | 7'10-1/2" |
| 9'2" | 8'10" | 8'2-1/2" |
| 9'6" | 9'2" | 8'6-1/2" |
| 9'11" | 9'6" | 8'10" |

Notes

1. Pits must always be protected by a sliding shutterdoor (even in underground garages).
2. Arrangements start with 2 grids for 3 cars, 3 grids for 5 cars.
3. Installation length of 18' for car length of a max. of 16'5". Clear platform width of 8'2-1/2" for car widths of 6'3" cm. For large touring sedans we recommend a clear platform width of at least 8'6-1/2" - 8'10-1/4".
4. For large touring sedans an installation length of 18'8-1/2" is recommended. This length offers larger safety distances for potential future developments or projects with short term parkers such as hotels or similar.
5. It is not possible to have channels or undercuts and/or concrete haunches along the pit's rear and front floor-to-wall joints. In the event that channels or undercuts are necessary, the pit length needs to be increased based on the dimensions of said channels or undercuts.
6. The manufacturer reserves the right to construction or model modifications and/or alterations. Furthermore, the right to any subsequent part modification and/or variations and amendments in procedures and standards due to technical and engineering progresses in the art or due to environmental regulation changes, are also hereby reserved.

Doors

The Combilift 542 must be closed with shutterdoors. The door controls are integrated in the overall system. That means:

- The doors are electro-mechanically interlocked.
- The doors can only be opened when the selected parking place has reached the entry/exit position.
- Any pits are closed in the entrance area.

Local requirements for electrical doors regarding the technology, maintenance and revision are not subject of our delivery. These matters have to be observed and carried out by the customer, according to the local regulations.

DOOR TYPES:

Manually operated sliding shutterdoors

- for underground garages with galvanised barred metal panelling
- above ground with powder coated metal sheets (RAL 7030)

Alternatively, sliding shutterdoors can be supplied with electrical drive.

Installation:

Behind the building pillars with door offset

SECTION

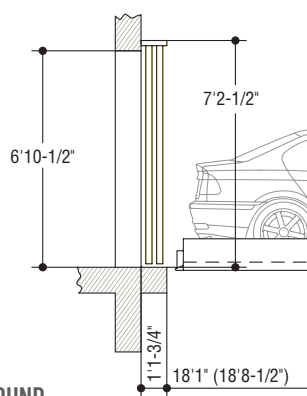

GROUND PLAN

- = 10" for manually operated sliding shutterdoors
- = 1'1-3/4" for automatic shutterdoors

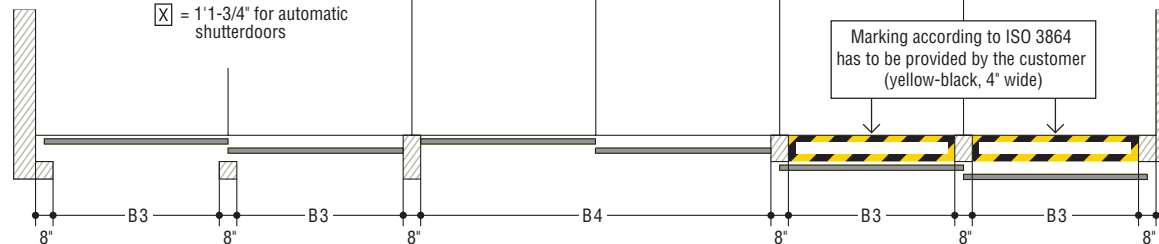

Installation:

Below the lintel between the building pillars

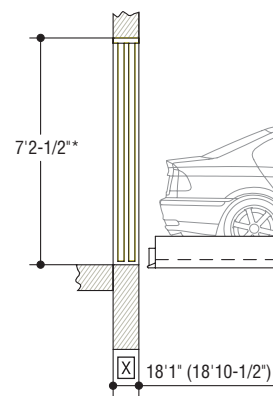

Installation:

In front of the building pillars

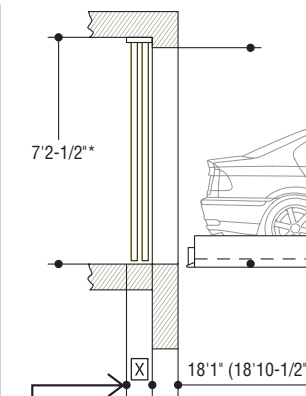

With installation in front of the pillars, the driving aisle is measured from the door.

Marking according to ISO 3864 has to be provided by the customer (yellow-black, 4" wide)

| SPACE REQUIRED | | GIVES CLEAR PLATFORM WIDTH |
|----------------|-----------|----------------------------|
| B3 | B4 | |
| 7'6-1/2" | 15'9" | 7'6-1/2" |
| 7'10-1/2" | 16'5" | 7'10-1/2" |
| 8'2-1/2" | 17'1/2" | 8'2-1/2" |
| 8'6-1/4" | 17'8-1/2" | 8'6-1/4" |
| 8'10-1/4" | 18'4-1/2" | 8'10-1/4" |

* The lintel of 7'2-1/2" is absolutely necessary. With differing heights, additional fixings are required at a surcharge. If no lintel is provided, the gates need to be fitted onto a steel frame (subject to surcharges).

Sliding Door Floor Guides in Underground Garages

The evenness or flatness of the floor in the bottom floor guide section is required to comply with ASTM FL25 standard requirements.

The bottom floor guides are composed of plastic rollers, locked down onto floor mounted base plates.

Anchor depth to be approx. 3-1/2".

Note: In the event that floor filling needs to be laid into the door section to the purpose of reaching the required floor evenness, the borehole depth needs to be increased by the thickness of the floor fill (for a max of 1-1/2").

FRONT VIEW

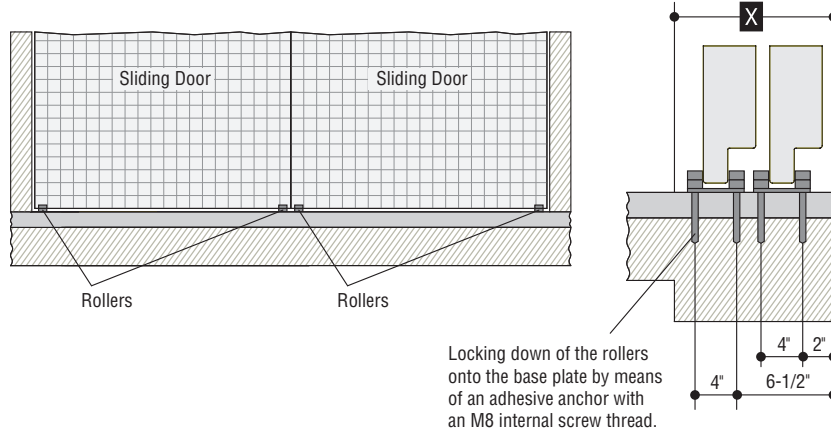

Sliding Door Floor Guides in Above Ground Garages

The evenness or flatness of the floor in the bottom floor guide section is required to comply with ASTM FL25 standard requirements.

The bottom floor guides are composed of guide rails, locked down onto the floor.

Anchor depth to be approx. 3-1/8".

Note: In the event that floor filling needs to be laid into the door section to the purpose of reaching the required floor evenness, the borehole depth needs to be increased by the thickness of the floor fill (for a max of 1-1/2").

FRONT VIEW

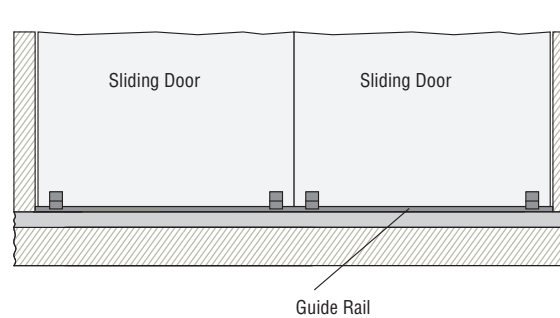

SECTION

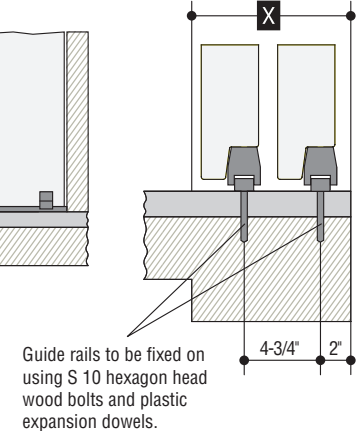

Width Dimensions and Statics

All dimensions shown are minimum. Constructional tolerances must be taken into consideration. All dimensions in feet and inches.

SECTION

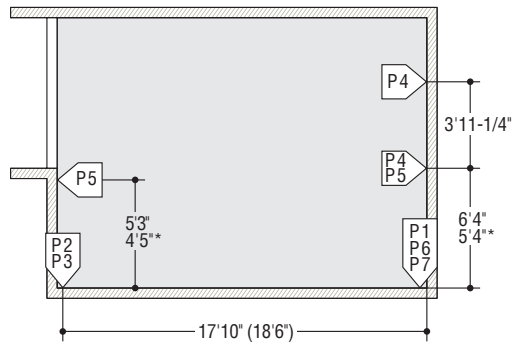

| | |
|------|---------|
| P1 = | +42,0KN |
| P2 = | +29,0KN |
| P3 = | +15,0KN |
| P4 = | ±5,0KN |
| P5 = | ±2,5KN |
| P6 = | ±15,0KN |
| P7 = | ±8,0KN |

Bearing loads are transmitted by wall plates with min. 4.65"² surface and to the floor by base plates with min. 54.25"² surface.

The wall and floor plates are attached with adhesive anchor bolts. Hole depth 4"-4-3/4".

The bottom plate, the wall at the entrance side and the rear wall are to be made of concrete and must be at least 7" thick! They must be perfectly level and must not have any protruding parts such as edge frames, pipes, etc.

Concrete quality according to the static building requirements, however for the dowel fixing concrete quality of min. C20/25 is required.

The specified lengths to the support points are mean values. If the support points must be placed precisely, individual sheets are available for every execution type.

Please contact Harding Autopark Systems to clarify the door widths/widths of columns. Grid width of 8'2-1/2" / 8'6-1/4" / 8'10-1/4" / 9'2-1/4" / 9'6" must be observed.

() Dimensions in brackets for longer units

* Dimensions for compact type

1) All static loadings include the weight of the car

GROUND PLAN

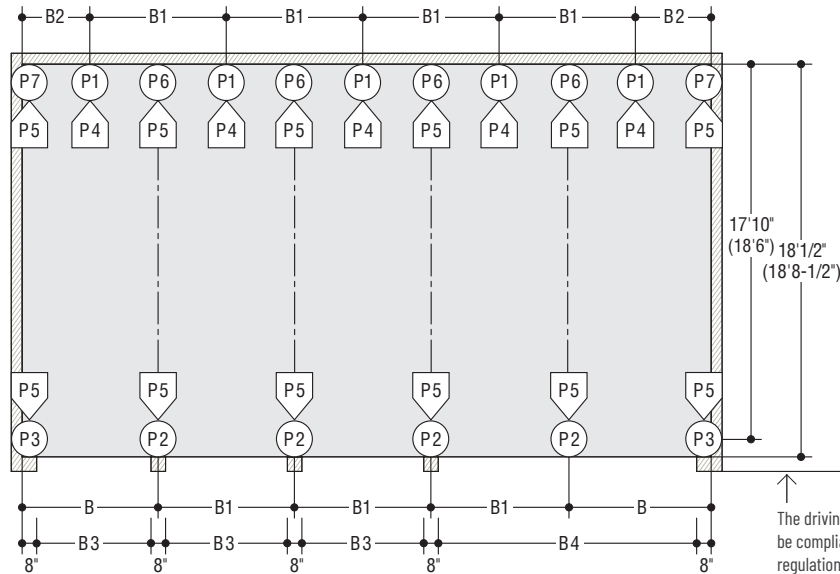

| B | SPACE REQUIRED | | | | GIVES CLEAR PLATFORM WIDTH |
|-----------|----------------|-------|-----------|-----------|----------------------------|
| | B1 | B2 | B3 | B4 | |
| 8'6-1/4" | 8'2-1/2" | 4'5" | 7'6-1/2" | 15'9" | 7'6-1/2" |
| 8'10-1/4" | 8'6-1/4" | 4'7" | 7'10-1/2" | 16'4-3/4" | 7'10-1/2" |
| 9'2-1/4" | 8'10-1/4" | 4'9" | 8'2-1/2" | 17'3/4" | 8'2-1/2" |
| 9'6" | 9'2-1/4" | 4'11" | 8'6-1/4" | 17'8-1/2" | 8'6-1/4" |
| 9'11" | 9'6" | 5'1" | 8'10-1/4" | 18'4-1/2" | 8'10-1/4" |

NOTICE: If the width of the columns is more than 8", then the width of the drive through will be reduced accordingly to the above mentioned width dimensions. In order to avoid this, we recommend to extend the distance between the columns (B3 and B4) accordingly. Please contact Harding Autopark Systems.

HYDRAULIC POWER PACKS

The hydraulic power pack is positioned within the system.

SWITCH CABINET

The switch cabinet is positioned within the system at the rear wall.

ELECTRICAL DATA

Connection 208-230V, 50/60Hz, 3 Phase. power consumption max. 3.5 kW.
Fuse or circuit breaker 3 x 30A slow blow and supply line 3Ph+N+PE (according to local regulations) up to the main switch, and connection of the supply line is performed by customer

Grounding and potential equalisation:

- to be performed by the customer compliant to DIN EN 60204
- connections required every 32'

GENERAL PRODUCT INFORMATION

The entrance level parking place row has one place less than the lower level. This empty space always stays on entrance floor level.

The platforms at the entrance floor level are shifted sideways by one space so that the empty space is above the lower level platform to be raised.

HOTEL GARAGE

If used by hotel guests, the installation requires special planning and construction. Please ask for details.

NOISE PROTECTION

Basis is the German DIN 4109 "Noise protection in buildings".

With the following conditions required 30 dB (A) in rooms can be provided:

- noise protection package from our accessory
- insulation figure of the construction of min. R'w = 57dB
- walls which are bordering the parking systems must be done as single wall and deflection resistant with min. m' = 300 kg/m²
- solid ceiling above the parking systems with min. m' = 400 kg/m²

At differing constructional conditions additional sound absorbing measures are to be provided by the customer.

The best results are reached by separated sole plates from the construction.

Increased noise protection:

If increased noise protection must be provided planning has to be confirmed on a project basis by Harding Autopark Systems.

TEMPERATURE

The installation is designed to operate between +5° and +40°C.

Atmospheric Humidity: 50% at +40°C. If the local circumstances differ from the above please contact Harding Autopark Systems.

CONFORMITY TEST

All our systems are checked according to EC machinery directive 2006/42/EC and EN 14010.

ILLUMINATION

Illumination has to be considered acc. to local requirements by the customer.

NUMBERING OF THE PARKING SPACES

1. The empty space of the Combilift is always on the left in the entrance level.
2. The numbering is as follows:

| | | | | | |
|----|---|---|---|---|---|
| EG | | 2 | 4 | 6 | 8 |
| UG | 1 | 3 | 5 | 7 | 9 |

3. The numbering for each system starts with 1 as above.
4. Different numbering of parking spaces is possible at a surcharge (software changes are necessary).

FREE SPACES

Special drawings for free spaces to accommodate air ducts or other pipes can be requested at Harding Autopark Systems!

RAILINGS

If walkways are arranged directly to the side or behind the systems, railings have to be provided by the customer acc. to local requirements, height min. 6'6-3/4" - this is applicable during the construction phase too.

DRAINAGE

We recommend providing gutter in the pit centre and connecting the gutter either to a gully or a drainage pit 1'7-1/2" x 1'7-1/2" x 8". If the pump sump is not accessible for manual drainage, the client must provide a pump on site to empty the pump sump. Lateral slope only within the gutter. To prevent hazards for the ground water, we recommend giving the pit floor an oil-resistant coating as a means of protecting the environment. If this is to be connected to the sewage system, it is advisable to provide oil/water separators.

MAINTENANCE

Preventative maintenance services available through Harding Autopark Systems.

PROTECTION AGAINST CORROSION

Periodic cleaning of system according to Maintenance Instructions must be carried out in addition to regularly scheduled maintenance by Harding Autopark Systems.

Clean up galvanized parts and platforms of dirt and road salt as well as other pollution (corrosion danger)!

Pit must always be well ventilated.

PARKING PLACE WIDTH

We recommend a clear platform width of at least 8'2-1/2".

DIMENSIONS

All dimensions shown are minimum. Construction tolerances must be taken into consideration. All dimensions in inches.

FIRE SAFETY

Each and every fire safety requirement and all possible mandatory item(s) and equipment(s) (fire extinguishing systems and fire alarm systems, etc.) are to be provided by the customer.

CLEARANCE PROFILE (STANDARD SALOON/ESTATE CAR)

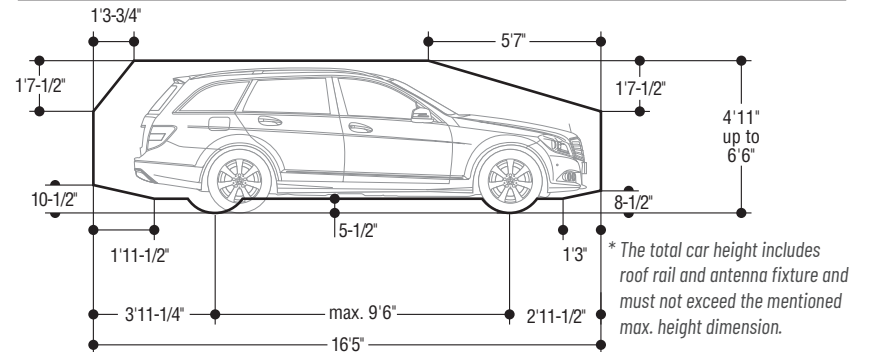

NOTES

We recommend providing wiring conduits leading to operating panels, particularly in above-ground garages. The wiring conduits should be placed 4' above entrance level in a support in the middle of the area.